



**Canflex (USA), Inc.**

Your best choice for flexible containment!

**HEAVY DUTY  
BEACH SEALING OIL BOOMS**

Manufactured with high strength urethane coated fabric

**BB-800 - For shallow waters, intertidal waters, and calm rivers**

“Beach Sealing Oil Boom” is widely used for oil spill response and environmental operations. The water ballast containment booms are used to protect areas exposed to tidal flow. It is ideal for sealing land-water interface in shallow waters, calm rivers, or intertidal waters. The beach boom has two interconnected bottom water chambers (ballast) with two fill/drain water valves and one top air chamber (buoyancy/towing) with one fill/drain air valve. All chambers have automatic relief valves which protect the unit from overpressure.

The Canflex Heavy Duty “Beach Sealing Oil Boom” is manufactured using a 35.3 oz/yd<sup>2</sup> (1,200 g/m<sup>2</sup>) urethane coated, polyester fabric, giving it excellent durability and flexibility. Both ends of the boom are reinforced to avoid tearing. Each section has two ASTM aluminum end quick connectors with stainless steel bolts and pin.



## BEACH SEALING OIL BOOM BB-800

### Top Features

- High abrasion resistant urethane coated fabric
- Reflective strips on the splash flaps allow for good visibility
- ASTM connectors at both ends of boom
- Top inflatable chamber is equipped with one (1 PSI) relief valve and one Monsun air fill valve
- Each of the two bottom ballast chambers are equipped with one (2 PSI) relief valve and one Monsun water filling valve
- 2" Interconnecting hose assembly with valve adapters (to fill/offload the fluid in series of up to 4 x 65ft sections at a time)
- Carry/Storage bag

### Technical Information

Property	BB-800
Height	31.5 in / 800 mm
Freeboard	15.75 in / 400 mm
Draft	15.75 in / 400 mm
End Connector	ASTM with toggle pin and sacrificial zinc anodes
Weight	7.0 lbs/ft 10.5 kg/m
Section Lengths	50 ft/ 65 ft/ 82 ft (15 m/ 20 m/ 25 m)
Material: (Urethane)	35.3 oz/yd <sup>2</sup> (1200 g/m <sup>2</sup> )
Base Fabric	Polyester 1500 Den/Polyester 1670 Dtx 14.2 x 15
Tensile Strength Strip	780 / 670 lbf/in (700 / 600 kg/ 5cm)
Tear Strength DIM	110 / 120 lbf (500 / 550 N)
Cold Crack/Bend	-58°F / -50°C
Accessories included	Repair Kit, Hand pump and Carry/Storage bag
Optional	Reinforced double layered base for added resistance against abrasive or jagged surfaces

MODEL	HEIGHT	FREEBOARD	DRAFT	DRY WEIGHT
	mm	mm	mm	Kg/m
BB-800	inch	inch	inch	lbs/ft
	800	400	400	10.5
	31.5	17.75	17.5	7.0

Section Length available: 50ft / 65ft / 82ft (15m / 20m / 25m)

**MADE IN  
USA**



MATERIAL CONSTRUCTION SPECIFICATIONS					
Urethane COATED TYPE	WEIGHT g/m <sup>2</sup> oz/yd <sup>2</sup>	FABRIC TYPE	FABRIC PROPERTIES	TENSILE STRENGTH lb/in <sup>2</sup> / N/cm <sup>2</sup>	PUNCTURE RESISTANCE Kg / lb
Oil & Water Resistant	1,200 / 35.3	Polyester	10,000 Cycles High Abrasion Resistance	7000 / 6000 / 780 / 670	190 / 420

Color- Orange or Yellow

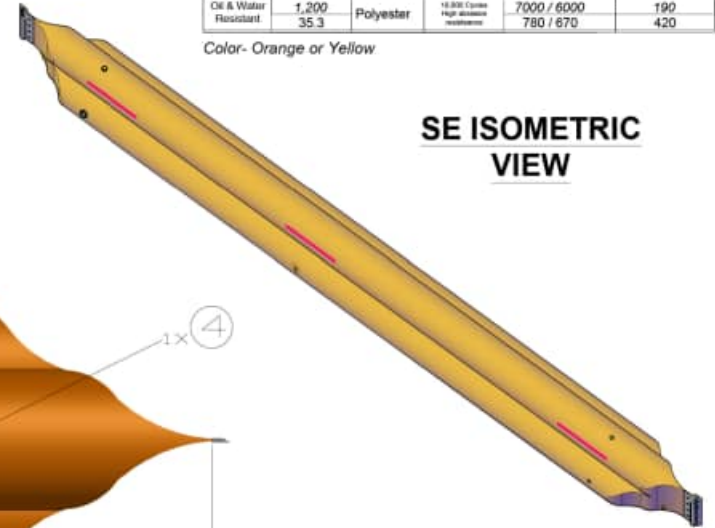

**SE ISOMETRIC  
VIEW**

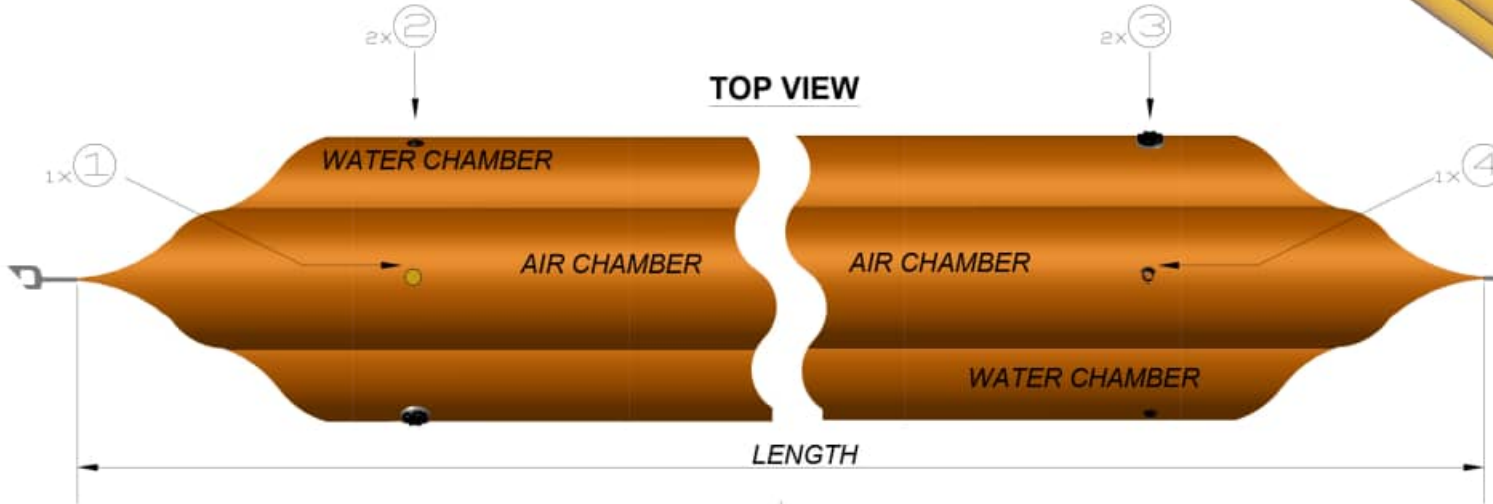

**TOP VIEW**

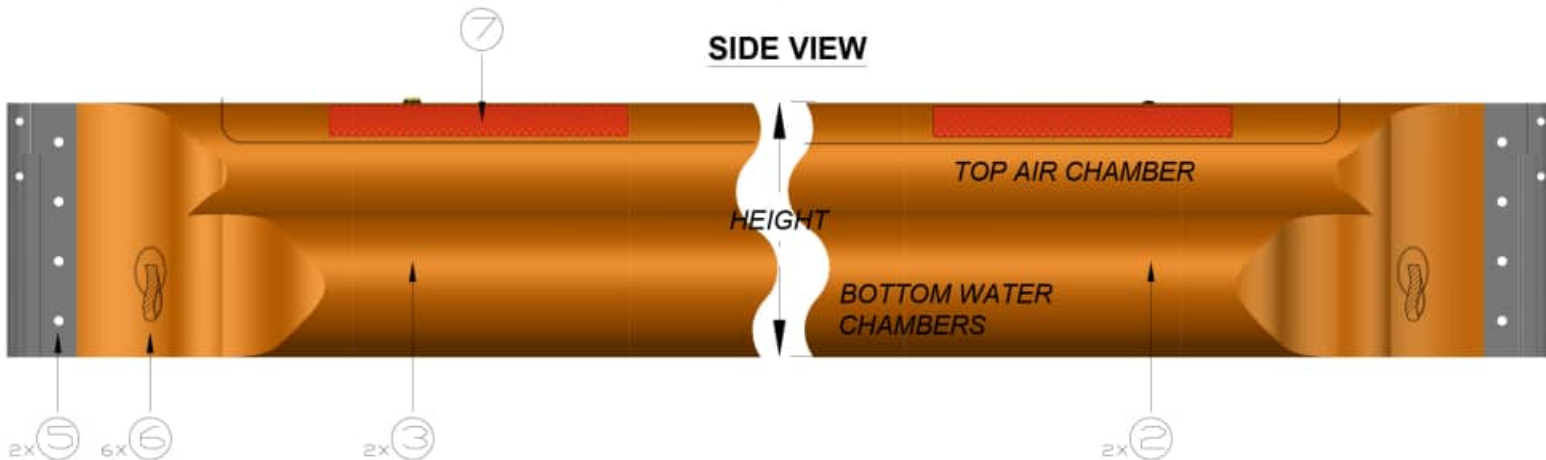

**SIDE VIEW**

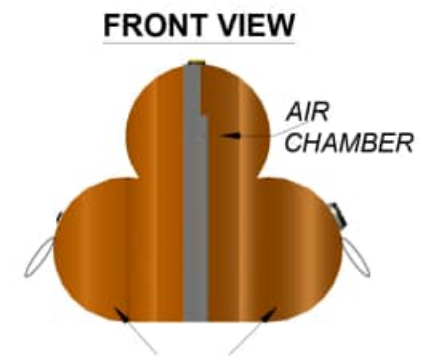

**FRONT VIEW**

ITEM NO.	QTY. REQD.	DESCRIPTION OF ITEM PER SECTION	PART #
1	1	1/2" AIR FILL/ OFFLOAD "MONSUN" VALVE	MSV1
2	2	FLUID RELIEF VALVE- 1 PSI	A10LP110PW
3	2	2" FLUID FILL/ OFFLOAD "MONSUN" VALVE	MXVII
4	1	AIR RELIEF VALVE- 1 PSI	A10LP110PW
5	2	ASTM CONNECTOR W/ BCKG PLATE ,TOGGLE PIN & ZINC ANODE	ASTM/24
6	6	500 WLL HEAVY DUTY HANDHOLD	HDL
7	6	2" LUMINOUS STRIP - ON BOTH SIDES	LMNS2



**PROJECT:  
HEAVY DUTY  
CANFLEX BEACH SEALING OIL BOOM**

SCALE: N.T.S	<b>MODEL: BB-800</b>	DRAWN BY: F.Y.
DATE: 10/14/2015		REVISED: 05/31/2024

**CANFLEX USA INC. PO BOX 1014 , 412 30th St , Anacortes,WA,98221,USA**  
**Tel:(206)282-8233; salesteam@canflexinc.com Web: www.canflexinc.com**