



Canflex (USA), Inc.

Your best choice for flexible containment!

BEACH SEALING OIL BOOMS

BB-650-E - For shallow waters, intertidal waters, and calm rivers

“Beach Sealing Oil Boom” is widely used for oil spill response and environmental operations. The water ballast containment booms are used to protect areas exposed to tidal flow. It is ideal for sealing land-water interface in shallow waters, calm rivers, or intertidal waters. The beach boom has two interconnected bottom water chambers (ballast) with two fill/drain water valves and one top air chamber (buoyancy/towing) with one fill/drain air valve. All chambers have automatic relief valves which protect the unit from overpressure.

The Canflex “Beach Sealing Oil Boom” is constructed using 100% “High Tenacity” PVC coated polyester fabric material. The fabric has a minimum weight of 27 oz/yd² (900 g/m²). The resulting seam strength of all welds is equal to or greater than the strength of the parent fabric. No gluing is used anywhere on the bag.



BEACH SEALING OIL BOOM BB-650-E

Top Features

- Reflective strips on the splash flaps allow for good visibility
- ASTM connectors at both ends of boom
- Top inflatable chamber is equipped with one (1 PSI) relief valve and one Monsun air fill valve
- Each of the two bottom ballast chambers are equipped with one (2 PSI) relief valve and one Monsun water filling valve
- 2" Interconnecting hose assembly with valve adapters (to fill / offload the fluid in series of up to 4 x 65ft sections at a time)

Technical Information

Property	BB-650-E
Height	26.0 in / 660 mm
Freeboard	13.0 in / 330 mm
Draft	13.0 in / 330 mm
End Connector	ASTM with toggle pin and sacrificial zinc anodes
Weight	3.35 lbs/ft 5.0 kg/m
Section Lengths	50 ft/ 65 ft/ 82 ft (15 m/ 20 m/ 25 m)
Material: (PVC)	27 oz/yd ² (900 g/m ²)
Base Fabric	Polyester
Tensile Strength Strip	457 / 457 lbf/in (4000 / 4000 N/ 5cm)
Tear Strength	124 / 112 lbf (550 / 500 N)
Cold Crack/Bend	-22°F / -30°C
Optional	Repair Kit, Hand Pump, Carry Bag/Storage Bag

MODEL	HEIGHT	FREEBOARD	DRAFT	DRY WEIGHT
	mm	mm	mm	Kg/m
BB-650E	660	330	330	5.0
	26.0	13.0	13.0	3.35

Section Length available: 50ft / 65ft / 82ft (15m / 20m / 25m)

**MADE IN
USA**



MATERIAL CONSTRUCTION SPECIFICATIONS

PVC COATED TYPE	WEIGHT g/m ² oz/yd ²	FABRIC TYPE	FABRIC PROPERTIES	TENSILE STRENGTH kN/5cm lbf/in	TEAR RESISTANCE N lbf
Oil & Water Resistant	900 27.0	Polyester	Oil Boom coastal use	4000 / 4000 457 / 457	550 / 500 124 / 112

Color- Orange or Yellow

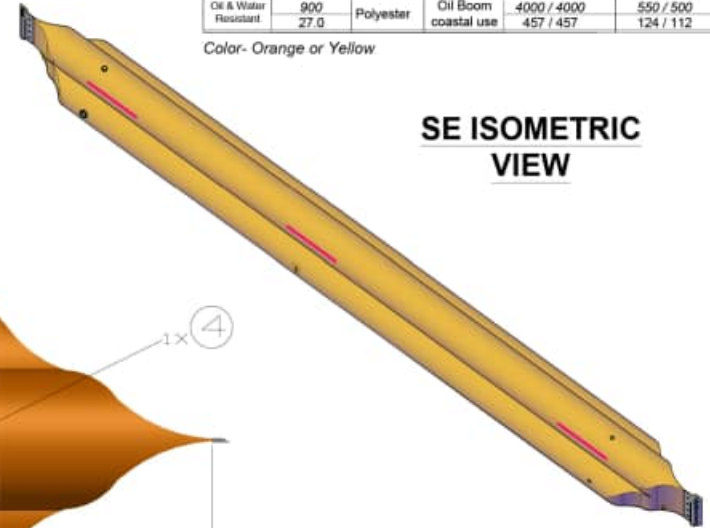

**SE ISOMETRIC
VIEW**

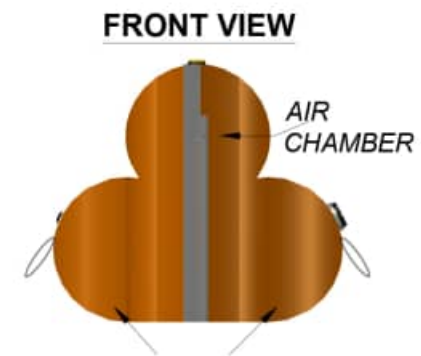
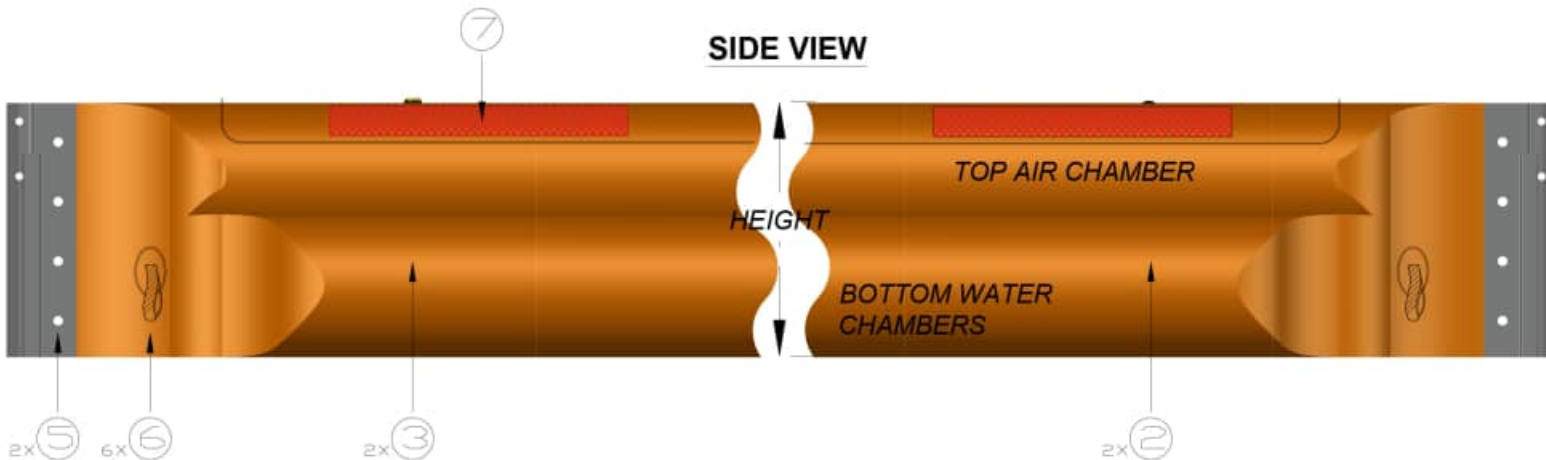
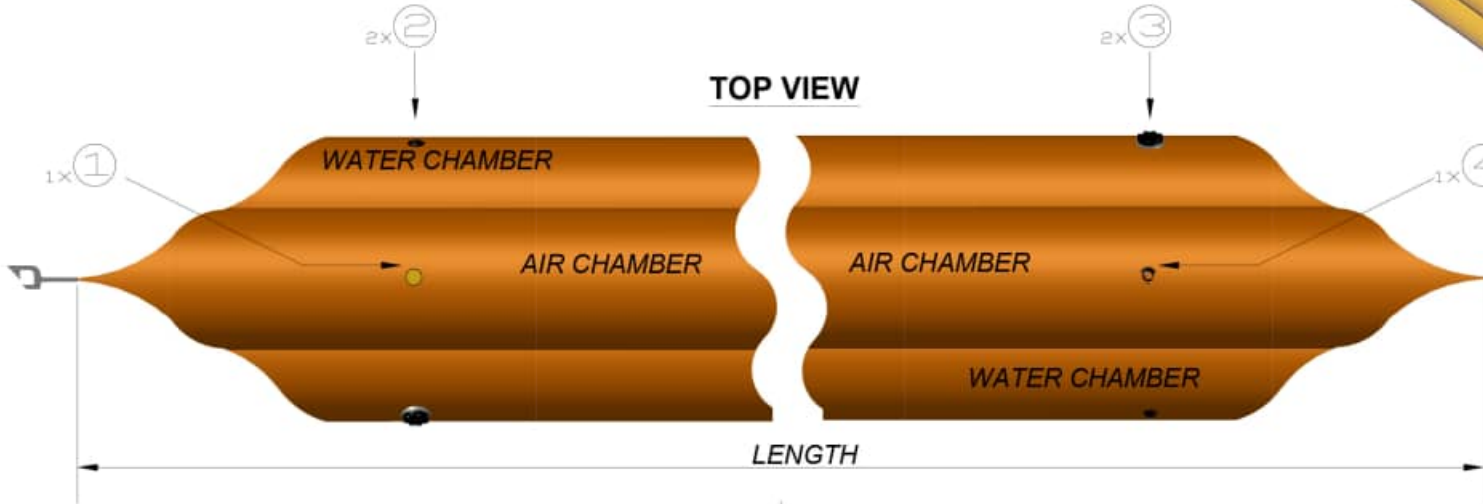

ITEM NO.	QTY. REQD.	DESCRIPTION OF ITEM PER SECTION	PART #
1	1	1/2" AIR FILL/ OFFLOAD "MONSUN" VALVE	MSV1
2	2	FLUID RELIEF VALVE- 1 PSI	A10LP110PW
3	2	2" FLUID FILL/ OFFLOAD "MONSUN" VALVE	MXVII
4	1	AIR RELIEF VALVE- 1 PSI	A10LP110PW
5	2	ASTM CONNECTOR W/ BCKG PLATE ,TOGGLE PIN & ZINC ANODE	ASTM/24
6	6	500 WLL HEAVY DUTY HANDHOLD	HDL
7	6	2" LUMINOUS STRIP - ON BOTH SIDES	LMNS2



**PROJECT:
CANFLEX BEACH SEALING OIL BOOM**

SCALE: N.T.S	MODEL: BB-650-E	DRAWN BY: F.Y.
DATE: 10/14/2015		REVISED: 05/31/2024

CANFLEX USA INC. PO BOX 1014 , 412 30th St , Anacortes,WA,98221,USA
Tel:(206)282-8233; salesteam@canflexinc.com Web: www.canflexinc.com