

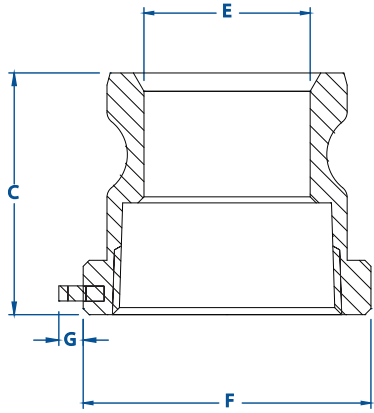

## PT COUPLING CO. GENERAL DIMENSIONS



**A - Adapter**

A - Adapter (ADAPTER X FEMALE THREAD)																
REF	DESCRIPTION	E05	05	07	10	12	15	20	25	30	40	50	60	80	100	120
	COUPLER OR ADAPTER SIZE	.50	.75	.75	1.00	1.25	1.50	2.00	2.50	3.00	4.00	5.00	6.00	8.00	10.00	12.00
	THREAD SIZE	.50	.50	.75	1.00	1.25	1.50	2.00	2.50	3.00	4.00	5.00	6.00	8.00	10.00	12.00
C	OVERALL LENGTH in/(mm)	1.60 (41)	1.62 (41)	1.62 (41)	1.91 (49)	2.16 (55)	2.29 (58)	2.54 (65)	2.75 (70)	2.84 (72)	3.16 (80)	3.22 (82)	3.35 (85)	4.50 (114)	4.50 (114)	4.38 (111)
E	INSIDE DIAMETER in/(mm)	.53 (13)	.66 (17)	.75 (20)	.88 (22)	1.04 (26)	1.35 (34)	1.72 (44)	2.14 (54)	2.80 (71)	3.78 (96)	4.79 (122)	5.90 (150)	7.80 (198)	10.10 (257)	12.00 (305)
F	ACROSS CORNERS in/(mm)	1.12 (28)	1.49 (38)	1.49 (38)	1.76 (45)	2.19 (56)	2.44 (62)	2.92 (74)	3.49 (89)	4.22 (107)	5.41 (137)	6.49 (165)	7.70 (196)	10.23 (260)	12.79 (325)	14.75 (375)
G	CHAIN LUG EXTENSION in/(mm)				.34 (9)	.34 (9)	.33 (8)	.31 (8)	.27 (7)	.44 (11)	.39 (10)	.35 (9)	.60 (15)	.60 (15)	.60 (15)	

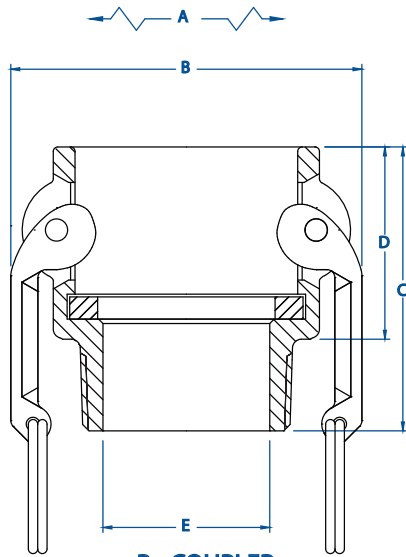

**B - COUPLER**

B - Coupler (COUPLER X MALE THREAD)																
REF	DESCRIPTION	E05	05	07	10	12	15	20	25	30	40	50	60	80	100	120
	COUPLER OR ADAPTER SIZE	.50	.75	.75	1.00	1.25	1.50	2.00	2.50	3.00	4.00	5.00	6.00	8.00	10.00	12.00
	THREAD SIZE	.50	.50	.75	1.00	1.25	1.50	2.00	2.50	3.00	4.00	5.00	6.00	8.00	10.00	12.00
A	O.D. WITH CAM ARMS EXTENDED in/(mm)	4.21 (107)	4.51 (115)	4.51 (115)	5.10 (130)	6.86 (174)	7.16 (182)	7.54 (192)	8.03 (204)	9.56 (243)	10.66 (271)	11.67 (296)	16.26 (413)	18.23 (463)	20.66 (525)	22.72 (577)
B	OUTSIDE DIAMETER in/(mm)	1.82 (46)	2.11 (54)	2.11 (54)	2.44 (62)	3.26 (83)	3.56 (90)	3.94 (100)	4.43 (113)	5.46 (139)	6.56 (167)	7.57 (192)	10.16 (258)	12.13 (308)	14.56 (370)	16.62 (422)
C	OVERALL LENGTH in/(mm)	2.10 (53)	2.10 (53)	2.10 (53)	2.50 (64)	2.89 (73)	2.93 (74)	3.20 (81)	3.63 (92)	3.82 (97)	4.00 (102)	4.20 (107)	4.52 (115)	4.80 (122)	5.50 (140)	5.70 (145)
D	EXPOSED LENGTH in/(mm)	1.25 (32)	1.25 (32)	1.25 (32)	1.56 (40)	1.84 (47)	1.88 (48)	2.15 (55)	2.18 (55)	2.27 (58)	2.34 (59)	2.44 (62)	2.62 (67)	2.72 (69)	3.20 (81)	3.20 (81)
E	INSIDE DIAMETER in/(mm)	.56 (14)	.56 (14)	.78 (20)	.97 (25)	1.25 (32)	1.50 (38)	1.88 (48)	2.38 (60)	2.88 (73)	3.60 (91)	4.50 (114)	5.60 (142)	7.50 (191)	9.40 (239)	11.40 (290)

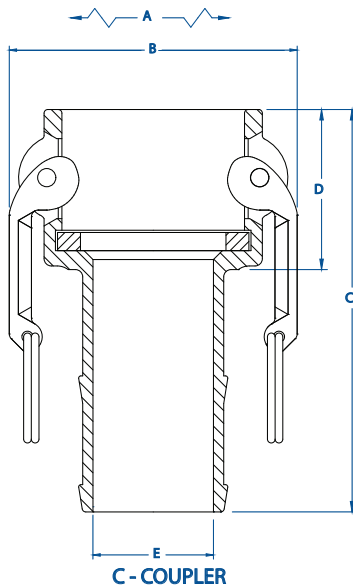

**C - COUPLER**

C - Coupler (COUPLER X HOSE SHANK)																
REF	DESCRIPTION	E05	05	07	10	12	15	20	25	30	40	50	60	80	100	120
	COUPLER OR ADAPTER SIZE	.50	.75	.75	1.00	1.25	1.50	2.00	2.50	3.00	4.00	5.00	6.00	8.00	10.00	12.00
	HOSE SHANK SIZE	.50	.50	.75	1.00	1.25	1.50	2.00	2.50	3.00	4.00	5.00	6.00	8.00	10.00	12.00
A	O.D. WITH CAM ARMS EXTENDED in/(mm)	4.21 (107)	4.51 (115)	4.51 (115)	5.10 (130)	6.86 (174)	7.16 (182)	7.54 (192)	8.03 (204)	9.56 (243)	10.66 (271)	11.67 (296)	16.26 (413)	18.23 (463)	20.66 (525)	22.72 (577)
B	OUTSIDE DIAMETER in/(mm)	1.82 (46)	2.11 (54)	2.11 (54)	2.44 (62)	3.26 (83)	3.56 (90)	3.94 (100)	4.43 (113)	5.46 (139)	6.56 (167)	7.57 (192)	10.16 (258)	12.13 (308)	14.56 (370)	16.62 (422)
C	OVERALL LENGTH in/(mm)	2.69 (68)	2.7 (69)	3.55 (90)	4.06 (103)	4.44 (113)	4.82 (122)	5.53 (140)	5.93 (151)	6.32 (161)	6.64 (169)	7.24 (184)	9.5 (241)	9.5 (241)	12 (305)	12 (305)
D	EXPOSED LENGTH in/(mm)	1.25 (32)	1.25 (32)	1.25 (32)	1.56 (40)	1.84 (47)	1.88 (48)	2.15 (55)	2.18 (55)	2.27 (58)	2.34 (59)	2.44 (62)	2.7 (69)	2.72 (69)	3.2 (81)	3.3 (81)
E	INSIDE DIAMETER in/(mm)	0.38 (10)	0.38 (10)	0.53 (13)	0.78 (20)	0.97 (25)	1.22 (31)	1.71 (43)	2.16 (55)	2.65 (67)	3.53 (90)	4.53 (115)	5.53 (140)	7.53 (191)	9.4 (239)	11.4 (290)



## PT COUPLING CO. GENERAL DIMENSIONS

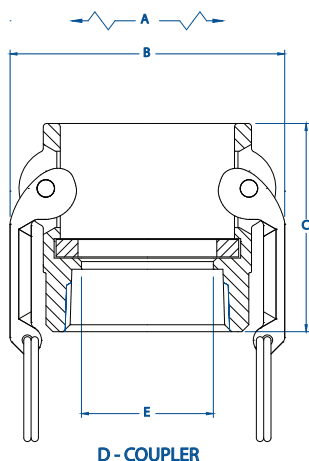

D - Coupler (COUPLER X FEMALE THREAD)																
REF	DESCRIPTION	E05	05	07	10	12	15	20	25	30	40	50	60	80	100	120
	COUPLER OR ADAPTER SIZE	.50	.75	.75	1.00	1.25	1.50	2.00	2.50	3.00	4.00	5.00	6.00	8.00	10.00	12.00
	THREAD SIZE	.50	.50	.75	1.00	1.25	1.50	2.00	2.50	3.00	4.00	5.00	6.00	8.00	10.00	12.00
A	O.D. WITH CAM ARMS EXTENDED in/(mm)	4.21 (107)	4.51 (115)	4.51 (115)	5.10 (130)	6.86 (174)	7.16 (182)	7.54 (192)	8.03 (204)	9.56 (243)	10.66 (271)	11.67 (296)	16.26 (413)	18.23 (463)	20.66 (525)	22.72 (577)
B	OUTSIDE DIAMETER in/(mm)	1.82 (46)	2.11 (54)	2.11 (54)	2.44 (62)	3.26 (83)	3.56 (90)	3.94 (100)	4.43 (113)	5.46 (139)	6.56 (167)	7.57 (192)	10.16 (258)	12.13 (308)	14.56 (370)	16.62 (422)
C	OVERALL LENGTH in/(mm)	2 (51)	2.1 (53)	2.1 (53)	2.5 (64)	2.7 (69)	2.8 (71)	3.1 (79)	3.4 (86)	3.5 (89)	3.9 (99)	4.1 (104)	4.4 (112)	4.8 (122)	5.5 (140)	5.7 (145)
E	INSIDE DIAMETER in/(mm)	0.67 (17)	0.67 (17)	0.88 (22)	0.97 (25)	1.25 (32)	1.5 (38)	1.88 (48)	2.38 (60)	2.88 (73)	3.6 (91)	4.5 (114)	5.5 (140)	7.5 (191)	9.4 (239)	11.4 (290)

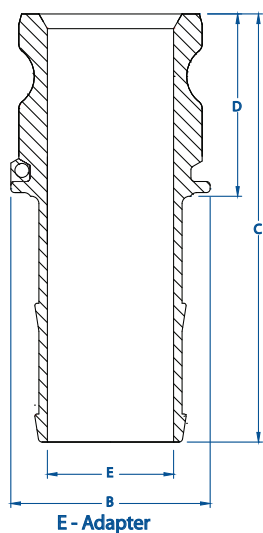

E - Adapter (ADAPTER X HOSE SHANK)																
REF	DESCRIPTION	E05	05	07	10	12	15	20	25	30	40	50	60	80	100	120
	COUPLER OR ADAPTER SIZE	.50	.75	.75	1.00	1.25	1.50	2.00	2.50	3.00	4.00	5.00	6.00	8.00	10.00	12.00
	HOSE SHANK SIZE	.50	.50	.75	1.00	1.25	1.50	2.00	2.50	3.00	4.00	5.00	6.00	8.00	10.00	12.00
B	OUTSIDE DIAMETER in/(mm)	0.96 (24)	1.26 (32)	1.26 (32)	1.63 (41)	2 (51)	2.14 (54)	2.64 (67)	3.07 (78)	3.70 (94)	4.71 (120)	6.56 (167)	7.1 (180)	9.1 (231)	11.37 (289)	13.46 (342)
C	OVERALL LENGTH in/(mm)	2.56 (65)	3.21 (82)	3.78 (96)	4.3 (109)	4.90 (124)	5.10 (130)	5.75 (146)	6.63 (168)	6.88 (175)	7.2 (183)	7.56 (192)	10.1 (257)	10.1 (257)	11.7 (297)	11.7 (297)
D	EXPOSED LENGTH in/(mm)	1.11 (28)	1.46 (37)	1.46 (37)	1.8 (46)	2.35 (60)	2.15 (55)	2.40 (61)	2.47 (63)	2.53 (64)	2.60 (66)	2.81 (71)	3.3 (84)	3.3 (84)	2.88 (73)	2.88 (73)
E	INSIDE DIAMETER in/(mm)	0.38 (10)	0.35 (9)	0.53 (13)	0.88 (22)	0.97 (25)	1.19 (30)	1.68 (43)	2.13 (54)	2.62 (67)	3.50 (89)	4.53 (115)	5.53 (140)	7.53 (191)	9.4 (239)	11.4 (290)

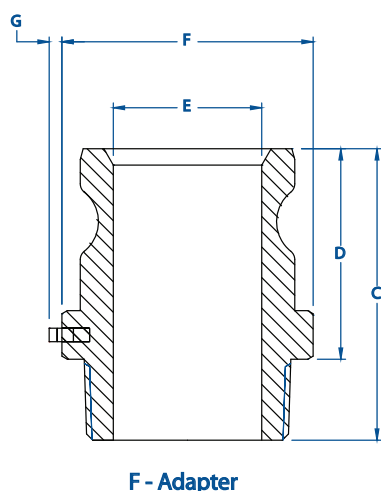

F - Adapter (ADAPTER X MALE THREAD)																
REF	DESCRIPTION	E05	05	07	10	12	15	20	25	30	40	50	60	80	100	120
	COUPLER OR ADAPTER SIZE	.50	.75	.75	1.00	1.25	1.50	2.00	2.50	3.00	4.00	5.00	6.00	8.00	10.00	12.00
	THREAD SIZE	.50	.50	.75	1.00	1.25	1.50	2.00	2.50	3.00	4.00	5.00	6.00	8.00	10.00	12.00
C	OVERALL LENGTH in/(mm)	1.96 (50)	2.47 (63)	2.47 (63)	2.89 (73)	3.23 (82)	3.29 (84)	3.57 (91)	4.18 (106)	4.37 (111)	4.79 (122)	4.91 (125)	5.20 (132)	5.90 (150)	6.75 (171)	7.2 (182)
D	EXPOSED LENGTH in/(mm)	1.26 (32)	1.67 (42)	1.67 (42)	1.99 (51)	2.23 (57)	2.31 (59)	2.57 (65)	2.78 (71)	2.87 (73)	3.19 (81)	3.21 (82)	3.40 (86)	3.90 (99)	4.38 (111)	4.80 (122)
E	INSIDE DIAMETER in/(mm)	0.53 (13)	0.56 (14)	0.75 (19)	0.85 (22)	1.04 (26)	1.34 (34)	1.72 (44)	2.14 (54)	2.80 (71)	3.78 (96)	4.79 (122)	5.84 (148)	7.80 (198)	9.88 (251)	12.00 (305)
F	MAX. ACROSS CORNERS in/(mm)	1.12 (28)	1.42 (36)	1.42 (36)	1.75 (45)	2.16 (55)	2.44 (62)	2.84 (72)	3.45 (88)	4.07 (103)	5.27 (134)	6.39 (162)	7.70 (196)	10.00 (254)	11.87 (301)	14.1 (358)
G	CHAIN LUG EXTENSION in/(mm)				.34 (9)	0.34 (9)	0.30 (8)	0.28 (7)	0.29 (7)	0.44 (11)	0.40 (10)	0.16 (4)	.60 (15)	.60 (15)	.60 (15)	



## PT COUPLING CO. GENERAL DIMENSIONS

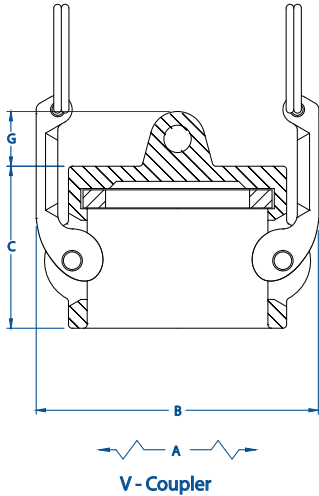

V - Coupler (COUPLER DUST CAP)																
REF	DESCRIPTION	E05	05	07	10	12	15	20	25	30	40	50	60	80	100	120
	COUPLER OR ADAPTER SIZE	.50		.75	1.00	1.25	1.50	2.00	2.50	3.00	4.00	5.00	6.00	8.00	10.00	12.00
A	O.D. WITH CAM ARMS EXTENDED in/(mm)	4.21 (107)		4.51 (115)	5.10 (130)	6.86 (174)	7.16 (182)	7.54 (192)	8.03 (204)	9.56 (243)	10.66 (271)	11.67 (296)	16.26 (413)	18.23 (463)	20.66 (525)	22.72 (577)
B	OUTSIDE DIAMETER in/(mm)	1.82 (46)		2.11 (54)	2.44 (62)	3.26 (83)	3.56 (90)	3.94 (100)	4.43 (113)	5.46 (139)	6.56 (167)	7.57 (192)	10.16 (258)	12.13 (308)	14.56 (370)	16.62 (422)
C	OVERALL LENGTH in/(mm)	1.3 (33)		1.35 (34)	1.60 (41)	1.89 (48)	1.96 (50)	2.25 (57)	2.28 (58)	2.27 (58)	2.34 (59)	2.44 (62)	2.76 (70)	2.72 (69)	3.30 (84)	3.50 (89)
G	CHAIN LUG EXTENSION in/(mm)	0.5 (13)		0.5 (13)	0.62 (16)	0.6 (15)	0.86 (22)	0.76 (19)	0.90 (23)	1.03 (26)	0.99 (25)	1.15 (29)	1.14 (29)	1.18 (30)	1.30 (33)	1.30 (33)

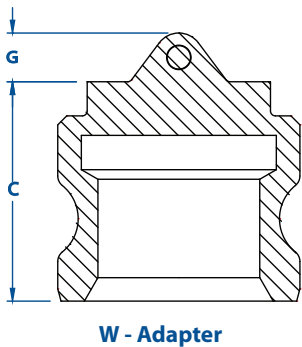

W - Adapter (ADAPTER DUST PLUG)																
REF	DESCRIPTION	E05	05	07	10	12	15	20	25	30	40	50	60	80	100	120
	COUPLER OR ADAPTER SIZE	.50		.75	1.00	1.25	1.50	2.00	2.50	3.00	4.00	5.00	6.00	8.00	10.00	12.00
C	OVERALL LENGTH in/(mm)	1.06 (27)		1.41 (36)	1.35 (34)	1.94 (49)	2.06 (52)	1.90 (48)	2.44 (62)	2.03 (52)	2.10 (53)	2.63 (67)	2.28 (58)	2.28 (58)	3 (76)	2.88 (73)
G	CHAIN LUG EXTENSION in/(mm)	.50 (13)		.59 (15)	.96 (24)	.62 (16)	.50 (13)	.70 (18)	.81 (21)	1.00 (25)	1.00 (25)	.85 (22)	1.00 (25)	1.18 (30)	0.9 (23)	.50 (13)



## PT COUPLING CO. GENERAL DIMENSIONS

PART PF-A (ADAPTER X FLANGE)												
REF	DESCRIPTION	PF10A	PF15A	PF20A	PF25A	PF30A	PF40A	PF50A	PF60A	PF80A	PF100A	PF120A
	ADAPTER SIZE	1.00	1.50	2.00	2.50	3.00	4.00	5.00	6.00	8.00	10.00	12.00
	FLANGE SIZE (ANSI CLASS 150)	1.00	1.50	2.00	2.50	3.00	4.00	5.00	6.00	8.00	10.00	12.00
C	OVERALL LENGTH in/(mm)	2.32 (59)	3.56 (90)	3.5 (89)	3.63 (92)	3.69 (94)	4.0 (102)	4.44 (113)	4.5 (114)	5.38 (137)	6.6 (168)	7.0 (178)
E	INSIDE DIAMETER in/(mm)	.88 (22)	1.34 (34)	1.72 (44)	2.14 (54)	2.78 (71)	3.78 (96)	4.79 (122)	5.56 (141)	7.8 (198)	10.0 (254)	11.4 (290)
F	OUTSIDE DIAMETER in/(mm)	4.25 (108)	5.0 (127)	6.0 (152)	7.0 (178)	7.5 (191)	9.0 (229)	10.0 (254)	11.0 (279)	13.5 (343)	16.0 (406)	19.0 (483)
J	BOLT HOLE DIAMETER in/(mm)	.63 (16)	.63 (16)	.75 (19)	.75 (19)	.75 (19)	.75 (19)	.88 (22)	.88 (22)	.88 (22)	1.0 (25)	1.0 (25)
K	NUMBER OF HOLES	4	4	4	4	4	8	8	8	8	12	12
L	BOLT CIRCLE DIAMETER in/(mm)	3.13 (80)	3.88 (99)	4.75 (121)	5.5 (140)	6.0 (152)	7.5 (191)	8.5 (216)	9.5 (241)	11.75 (298)	14.25 (362)	17.0 (432)

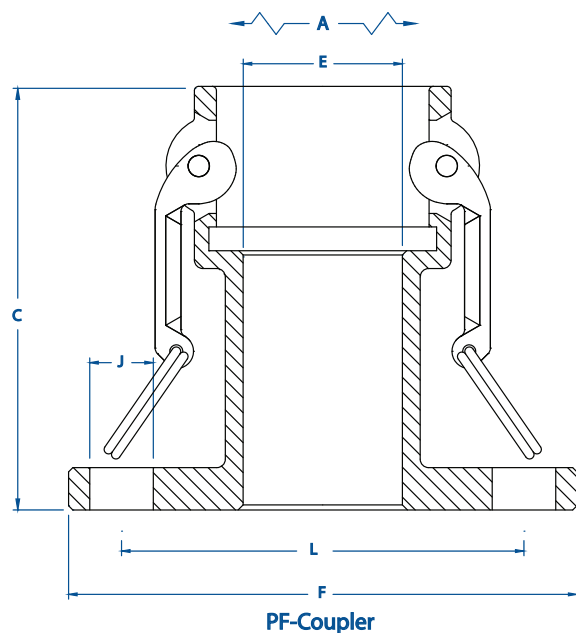
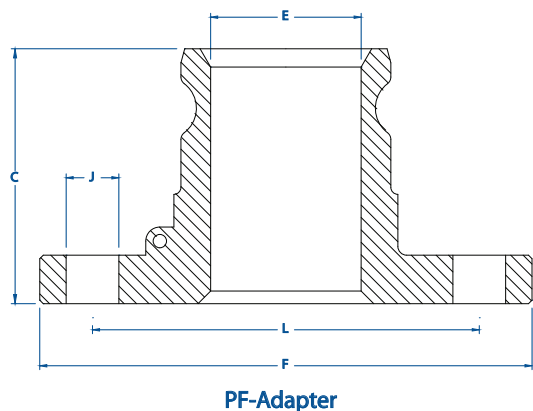

PART PF-C (COUPLER X FLANGE)											
REF	DESCRIPTION	PF10C	PF15C	PF20C	PF25C	PF30C	PF40C	PF60C	PF80C	PF100C	PF120C
	COUPLER SIZE	1.00	1.50	2.00	2.50	3.00	4.00	6.00	8.00	10.00	12.00
	FLANGE SIZE (ANSI CLASS 150)	1.00	1.50	2.00	2.50	3.00	4.00	6.00	8.00	10.00	12.00
A	O.D. WITH CAM ARMS EXTENDED in/(mm)	5.04 (128)	7.16 (182)	7.54 (192)	8.03 (204)	9.56 (243)	10.66 (271)	16.76 (426)	18.73 (476)	23.00 (599)	25.00 (635)
C	OVERALL LENGTH in/(mm)	3.48 (88)	5.25 (133)	5.82 (148)	5.09 (129)	5.82 (148)	5.39 (137)	7.75 (197)	7.64 (194)	8.5 (216)	8.5 (216)
E	INSIDE DIAMETER in/(mm)	.69 (18)	1.35 (34)	1.63 (41)	2.38 (60)	2.9 (74)	3.6 (91)	5.6 (142)	7.53 (191)	9.4 (239)	11.4 (290)
F	OUTSIDE DIAMETER in/(mm)	4.25 (108)	5.0 (127)	6.0 (152)	7.0 (178)	7.5 (191)	9.0 (229)	11.0 (279)	13.5 (343)	16.0 (406)	19.0 (483)
J	BOLT HOLE DIAMETER in/(mm)	.63 (16)	.63 (16)	.75 (19)	.75 (19)	.75 (19)	.75 (19)	.88 (22)	.88 (22)	1.0 (25)	1.0 (25)
K	NUMBER OF HOLES	4	4	4	4	4	8	8	8	12	12
L	BOLT CIRCLE DIAMETER in/(mm)	3.13 (80)	3.88 (99)	4.75 (121)	5.5 (140)	6.0 (152)	7.5 (191)	9.5 (241)	11.75 (298)	14.25 (362)	17.0 (432)



## PT COUPLING CO. GENERAL DIMENSIONS

TTF-A (ADAPTER X FLANGE)					
REF	DESCRIPTION	TTF20A	TTF30A	TTF40A	TTF60A
	ADAPTER SIZE	2.00	3.00	4.00	6.00
	FLANGE SIZE (TTMA)	2.00	3.00	4.00	6.00
C	OVERALL LENGTH in/(mm)	2.93 (74)	3.38 (86)	3.35 (85)	4.88 (124)
E	INSIDE DIAMETER in/(mm)	1.63 (41)	2.8 (71)	3.78 (96)	5.84 (148)
F	OUTSIDE DIAMETER in/(mm)	4.5 (114)	5.63 (143)	6.63 (168)	8.88 (226)
J	BOLT HOLE DIAMETER in/(mm)	.44 (11)	.44 (11)	.44 (11)	.44 (11)
K	NUMBER OF HOLES	6	8	8	12
L	BOLT CIRCLE DIAMETER in/(mm)	3.75 (95)	4.88 (124)	5.88 (149)	8.13 (207)

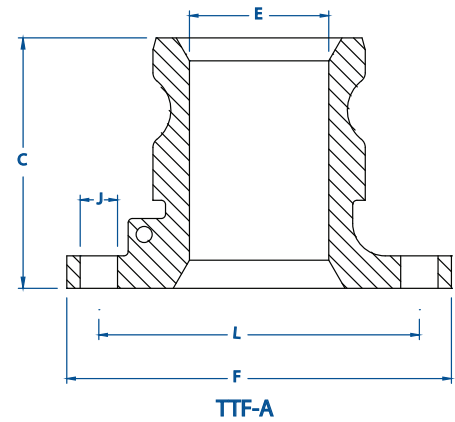

TTF-C (COUPLER X FLANGE)						
REF	DESCRIPTION	TTF20C	TTF30C	TTF40C	TTF60C	TTF80C
	COUPLER SIZE	2.00	3.00	4.00	6.00	8.00
	FLANGE SIZE (TTMA)	2.00	3.00	4.00	6.00	8.00
A	O.D. WITH CAM ARMS EXTENDED in/(mm)	7.54 (192)	9.56 (243)	10.66 (271)	16.26 (413)	18.23 (463)
C	OVERALL LENGTH in/(mm)	5.63 (143)	5.66 (144)	5.68 (144)	7.25 (184)	7.64 (194)
E	INSIDE DIAMETER in/(mm)	2.0 (51)	2.9 (74)	3.6 (91)	5.6 (142)	7.53 (191)
F	OUTSIDE DIAMETER in/(mm)	4.5 (114)	5.63 (143)	6.63 (168)	8.88 (226)	10.87 (276)
J	BOLT HOLE DIAMETER in/(mm)	.44 (11)	.44 (11)	.44 (11)	.44 (11)	.44 (11)
K	NUMBER OF HOLES	6	8	8	12	16
L	BOLT CIRCLE DIAMETER in/(mm)	3.75 (95)	4.88 (124)	5.88 (149)	8.13 (207)	10.12 (257)

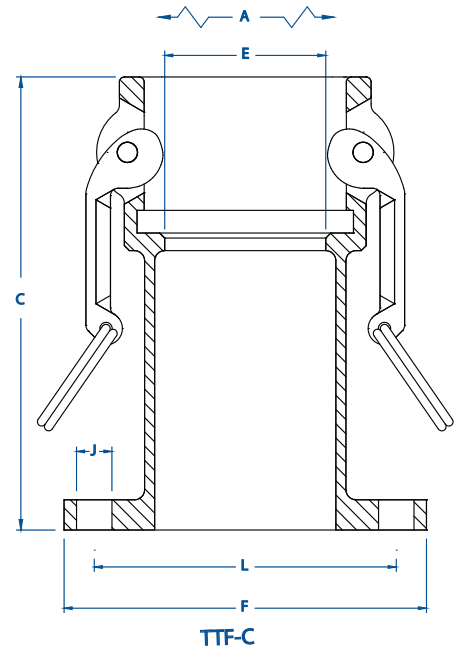

PT Coupling CO. Engagement Lengths																
DESCRIPTION	COUPLER/ADAPTER SIZE															
	E05	05	07	10	12	15	20	25	30	40	50	60	80	100	120	
ADAPTER/COUPLER. SIZE	0.50	0.75	0.75	1.00	1.25	1.50	2.00	2.50	3.00	4.00	5.00	6.00	8.00	10.00	12.00	
ADAPTER. ENGAGEMENT LENGTH	1.03	0.97	0.97	1.19	1.44	1.48	1.75	1.75	1.84	1.87	1.97	2.19	2.15	2.55	2.55	



# General Dimensions

## PT COUPLING CO. GENERAL SOCKET WELD DIMENSIONS

PART AWB (ADAPTER X BUTT WELD)														
DIM	DESCRIPTION	E05	07	10	12	15	20	25	30	40	50	60	80	100
A	OVERALL LENGTH	1.43	1.40	1.74	1.99	2.06	2.50	2.44	2.75	2.88	2.70	3.00	5.90	6.73
B	INSIDE DIAMETER	.53	.75	.88	1.06	1.25	1.75	2.14	2.81	3.75	4.75	5.84	7.80	9.90

PART DWB (COUPLER X BUTT WELD)														
DIM	DESCRIPTION	E05	07	10	12	15	20	25	30	40	50	60	80	100
A	O.D. WITH CAM ARMS EXTENDED	4.21	4.51	5.10	6.86	7.16	7.54	8.03	9.56	10.66	11.67	16.26	18.23	20.66
B	OUTSIDE DIAMETER	1.82	2.11	2.44	3.26	3.56	3.94	4.43	5.46	6.56	7.57	10.16	12.13	14.56
C	INSIDE DIAMETER	.56	.78	.97	1.25	1.54	1.88	2.38	2.88	3.50	4.50	5.50	7.50	9.40
D	OVERALL LENGTH	2.00	2.00	2.51	2.89	2.81	3.20	3.63	3.82	4.00	4.20	4.54	4.80	5.50

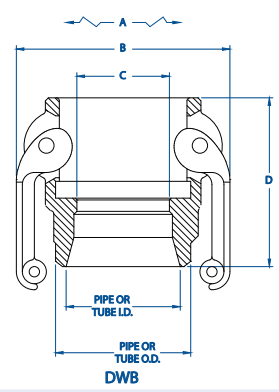
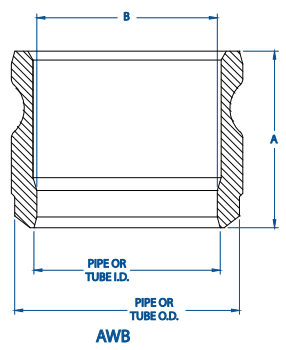

PART AWS (ADAPTER X SOCKET WELD)															
DIM	DESCRIPTION	E05	07	10	12	15	20	25	30	40	50	60	80	100	
A	SOCKET DEPTH	.30	.30	.30	.30	.40	.40	.40	.40	.60	.60	.60	.90	.90	
B	OUTSIDE DIAMETER	1.00	1.25	1.45	2.00	2.25	2.74	3.25	3.75	5.01	6.00	7.00	10.30	12.80	
C	INSIDE DIAMETER	.53	.75	.88	1.06	1.35	1.81	2.14	2.81	3.00	4.78	5.84	7.86	9.77	
D	OVERALL LENGTH	1.00	1.13	1.44	2.00	2.13	2.50	2.56	2.75	2.97	2.94	2.90	4.50	4.60	
E	SOCKET DIAMETER	PIPE	.88	1.10	1.36	1.71	1.95	2.44	2.94	3.57	4.58	5.66	6.72	8.74	10.89
		TUBE	.52	.77	1.02	1.27	1.52	2.02	2.52	3.02	4.03	5.03	6.03	8.04	10.05

PART DWS (COUPLER X SOCKET WELD)															
DIM	DESCRIPTION	E05	07	10	12	15	20	25	30	40	50	60	80	100	
A	O.D. WITH CAM ARMS EXTENDED	4.21	4.51	5.10	6.86	7.16	7.54	8.03	9.56	10.66	11.67	16.26	18.23	20.66	
B	OUTSIDE DIAMETER	1.82	2.11	2.44	3.26	3.56	3.94	4.43	5.46	6.56	7.57	10.16	12.13	14.40	
C	INSIDE DIAMETER	.56	.88	.97	1.25	1.50	1.88	2.38	2.88	3.60	4.50	5.50	7.50	9.40	
D	OVERALL LENGTH	2.00	2.06	2.50	2.70	2.81	3.10	3.40	3.50	3.90	4.20	4.54	4.80	5.50	
E	SOCKET DEPTH	.50	.50	.50	.50	.50	.70	.70	.70	.70	.90	.90	.90	.90	
F	SOCKET DIAMETER	PIPE	0.88	1.10	1.36	1.71	1.95	2.44	2.94	3.57	4.58	5.66	6.72	8.74	10.89
		TUBE	0.52	.77	1.02	1.27	1.52	2.02	2.52	3.02	4.03	5.03	6.03	8.04	10.05

